

Description

The SR70-LI is designed to protect sensitive components which are connected to data and transmission lines from over-voltages caused by ESD(electrostatic discharge), EFT(electrical fast transients), and lightning. The SR70-LI has been optimized for use on ADSL and other high-speed interfaces.

The unique design of the SR70-LI integrates four surge rated, low capacitance steering diodes in a low profile SOT-143 package. It has a typical capacitance of only 5pF and may be used to protect two high-speed lines without sacrificing signal integrity. The SR70-LI is designed to replace “standard” rectifiers that are not rated for the high energy surges that are normally expected in telecommunications applications.

During transient conditions, the steering diodes direct the transient to either the positive side of the power supply line or to ground. The maximum clamping voltage seen by the protected circuit will be one diode drop (VF) above the supply (reference) voltage. The SR70-LI may be used as a stand alone device or in conjunction with TVS diodes for enhanced protection.

Mechanical Characteristics

- ◆ Package: SOT-143
- ◆ UL 497B listed
- ◆ Molding compound flammability rating: UL 94V-0
- ◆ Marking: R70
- ◆ Packaging: Tape and Reel per EIA 481

Dimensions and Pin Configuration

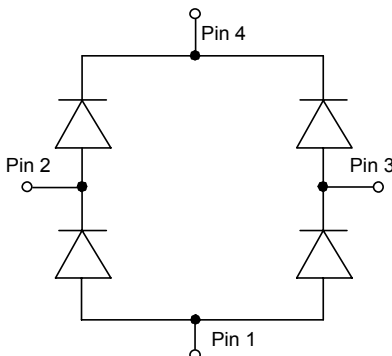

Circuit and Pin Schematic

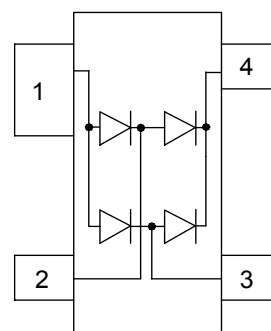

SOT-143 (Top View)

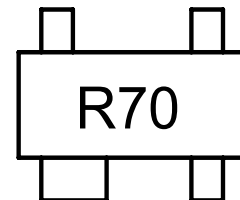

R70=Device Marking Code

Features

- ◆ Transient protection for high speed data lines to
 - IEC 61000-4-2 (ESD) immunity test
 - Air discharge: ±15kV
 - Contact discharge: ±8kV
 - IEC61000-4-4 (EFT) 40A (5/50ns)
 - IEC61000-4-5 (Lightning)1kV, 21A (8/20µs)
- ◆ Array of surge rated, low capacitance diodes
- ◆ Protects two I/O lines
- ◆ Low capacitance (1.5pF typical) for high-speed interfaces
- ◆ Low clamping voltage

Applications

- ◆ ADSL Lines
- ◆ I²C BUS Protection
- ◆ Video Line Protection
- ◆ T1/E1 secondary IC Side Protection
- ◆ Portable Electronics
- ◆ Microcontroller Input Protection
- ◆ WAN/LAN Equipment

Marking Information

Ordering Information

Part Number	Marking	Packaging	Reel Size
SR70-LI	R70	3000/Tape & Reel	7 inch

Absolute Maximum Ratings ($T_A=25^\circ\text{C}$ unless otherwise specified)

Parameter	Symbol	Value	Unit
Peak Pulse Current(8/20 μs)	I _{PP}	21	A
ESD per IEC 61000-4-2 (Air) ESD per IEC 61000-4-2 (Contact)	V _{ESD}	± 15 ± 8	kV
Operating Temperature Range	T _J	-55 to +125	$^\circ\text{C}$
Storage Temperature Range	T _{stg}	-55 to +150	$^\circ\text{C}$

Electrical Characteristics ($T_A=25^\circ\text{C}$ unless otherwise specified)

Parameter	Symbol	Min	Typ	Max	Unit	Test Condition
Reverse Working Voltage	V _{RWM}			70	V	
Punch-Through Voltage	V _{BR}	85			V	I _T = 50 μA
Reverse Leakage Current	I _R			0.5	μA	V _{RWM} = 70V
Clamping Voltage	V _C			3.0	V	I _{PP} = 1A (8 x 20 μs pulse)
Clamping Voltage	V _C			9.0	V	I _{PP} = 10A (8 x 20 μs pulse)
Clamping Voltage	V _C			16.0	V	I _{PP} = 21A (8 x 20 μs pulse)
Junction Capacitance	C _J		1.5		pF	V _R =0, f=1MHz, between I/O pins and Ground
Junction Capacitance	C _J		1.0		pF	V _R =0, f=1MHz, between I/O pins

Typical Performance Characteristics (TA=25°C unless otherwise Specified)

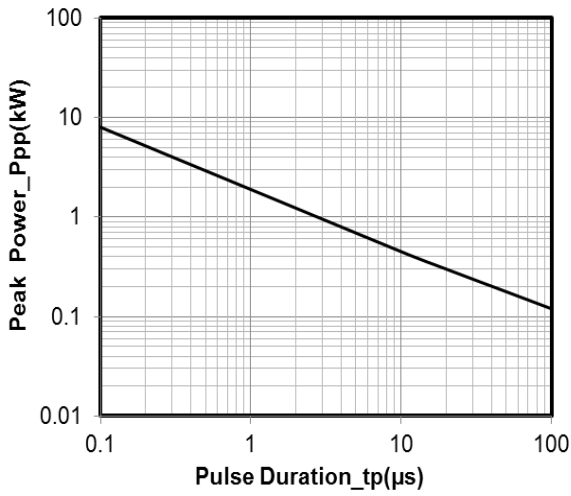

Peak Pulse Power vs. Pulse Time

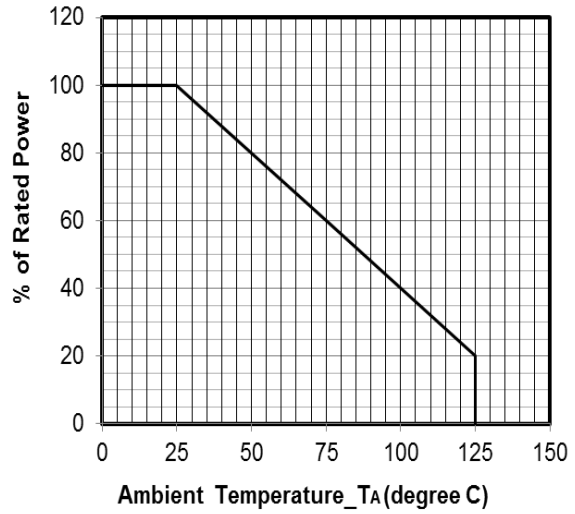

Power Derating Curve

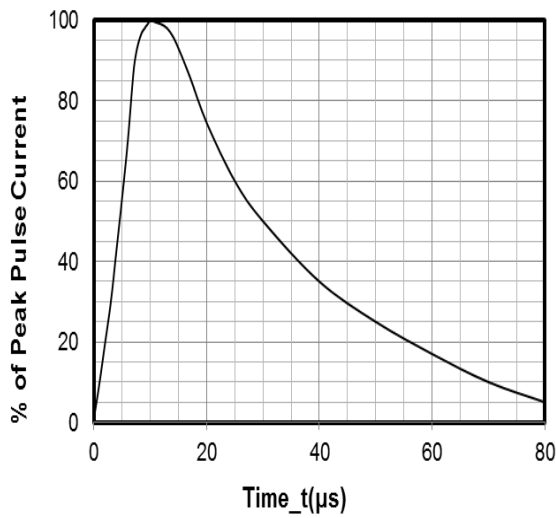

8 X 20μs Pulse Waveform

Applications Information

Applications Information

Device Connection Options for Protection of Two High-Speed Data Lines

The SR70-LI is designed to protect two data lines from transient over-voltages by clamping them to a fixed reference. When the voltage on the protected line exceeds the reference voltage (plus diode V_F) the steering diodes are forward biased, conducting the transient current away from the sensitive circuitry. Data lines are connected at pins 2 and 3. The negative reference (REF1) is connected at pin 1. This pin should be connected directly to a ground plane on the board for best results. The path length is kept as short as possible to minimize parasitic inductance.

The positive reference (REF2) is connected at pin 4. The options for connecting the positive reference are as follows:

1. To protect data lines and the power line, connect pins 2 and 3 directly to the positive supply rail (V_{CC}). In this configuration the data lines are referenced to the supply voltage. An external TVS diode may be added between the supply rail and ground in order to prevent over-voltage on the supply rail.
2. In applications where no positive supply reference is available, or complete supply isolation is desired, an external TVS diode may be used as the reference. The steering diodes will begin to conduct when the voltage on the protected line exceeds the working voltage of the TVS (plus one diode drop).

SR70-LI Pin Configuration

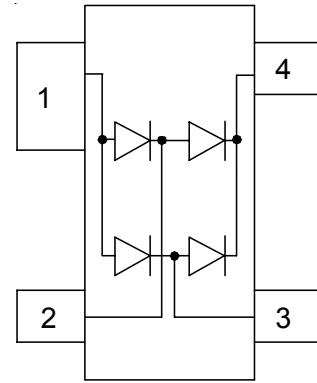

Data Line and Power Supply Protection Using Vcc as reference

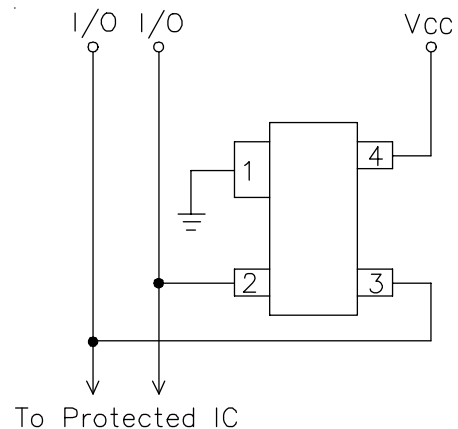

SOT-143 Package Outline Drawing

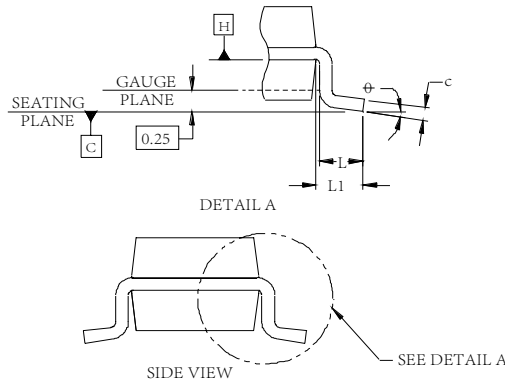
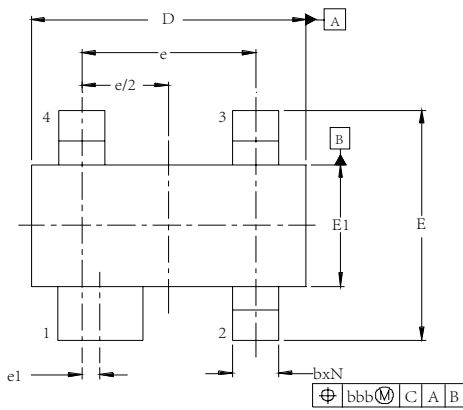

DIM	DIMENSIONS					
	INCHES			MILLIMETERS		
	MIN	NOM	MAX	MIN	NOM	MAX
A	.031	-	.048	0.80	-	1.22
A1	.000	-	.006	0.013	-	0.15
A2	.029	.035	.042	0.75	0.90	1.07
b	.011	-	.020	0.30	-	0.51
b1	.029	-	.037	0.76	-	0.94
c	.003	-	.008	0.08	-	0.20
D	.110	.114	.120	2.80	2.90	3.04
E	.082	.093	.104	2.10	2.37	2.64
E1	.047	.051	.055	1.20	1.30	1.40
e	.075			1.92 BSC		
e1	.008			0.20 BSC		
L	.015	.020	.024	0.40	0.50	0.60
L1	(0.021)			(0.54)		
N	4			4		
⊕	0°	-	8°	0°	-	8°
aaa	.006			0.15		
bb b	.008			0.20		
ccc	.004			0.10		

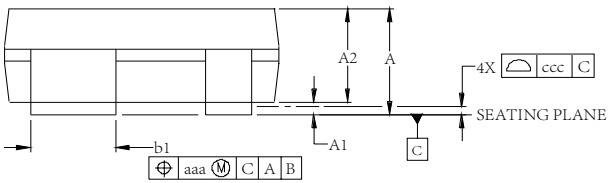

Suggested Land Pattern

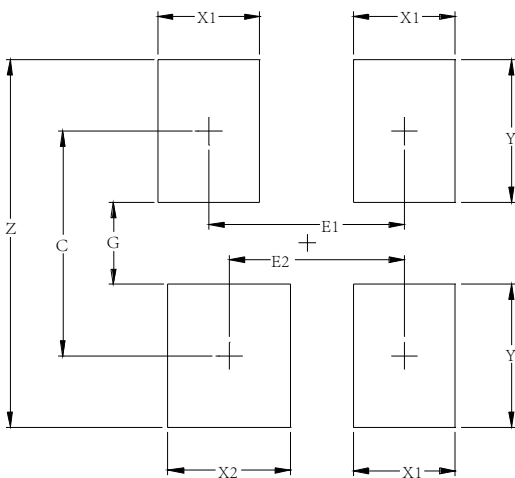

SYM	DIMENSIONS	
	MILLIMETERS	INCHES
C	2.20	0.087
E1	1.92	0.076
E2	1.72	0.068
G	0.80	0.031
X1	1.00	0.039
X2	1.20	0.047
Y	1.40	0.055
Z	3.60	0.141

Contact Information

Changzhou D-first Electronics CO.,Ltd.
 www.first-electronic.com
 Email: xhf@first-electronic.cn
 Phone: +86 (0519) 8817 1671